

PART NO	MODEL NO	TYPE	SIZE	MAX DESIGN VOLTS	CLIP SPACING	"A"	"B"	"C"	"D"	"E"	"F"	FIG NO
33	KLH/KLR 9F60	EJ-1	EE	15000	14.12	19.12	4.00	3.88	---	---	---	104
44	FPT	EJ-1	D	38000	27.00	30.81	3.00	2.625	3.25	2.75	3.125	105
45	HPT	EJ-1	DD	38000	27.00	30.81	3.00	2.625	3.25	2.75	3.125	106
48	RJD/RJF	EJO-5	C	5500	12.00	14.00	2.08	1.86	2.00	1.02	1.50	108



MERSEN USA NEWBURYPORT-MA, LLC
374 MERRIMAC STREET
NEWBURYPORT, MA 01950

TITLE
OUTLINE
FIRST MADE FOR CPO

32B608009
CONT ON SH SH 2

Types EJ-1 & EJO-1

Replaces 6210344, 158A8902, 173A8435

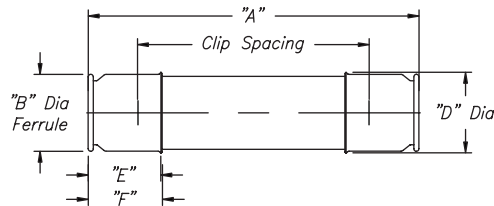

FIG 105

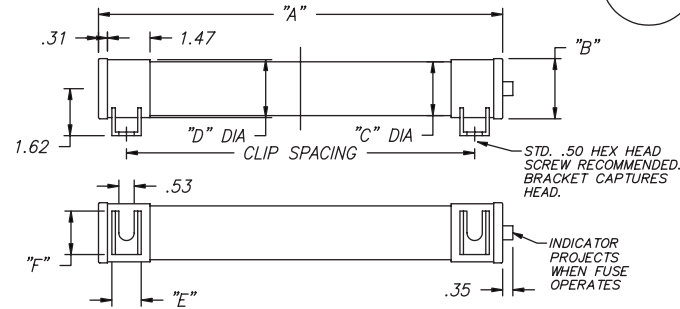

FIG 108

NOTES:
1. FUSE MOUNTING SURFACES MUST BE FLAT AND IN THE SAME PLANE.

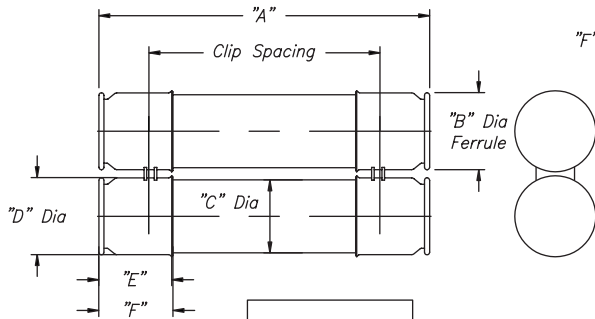

FIG 106

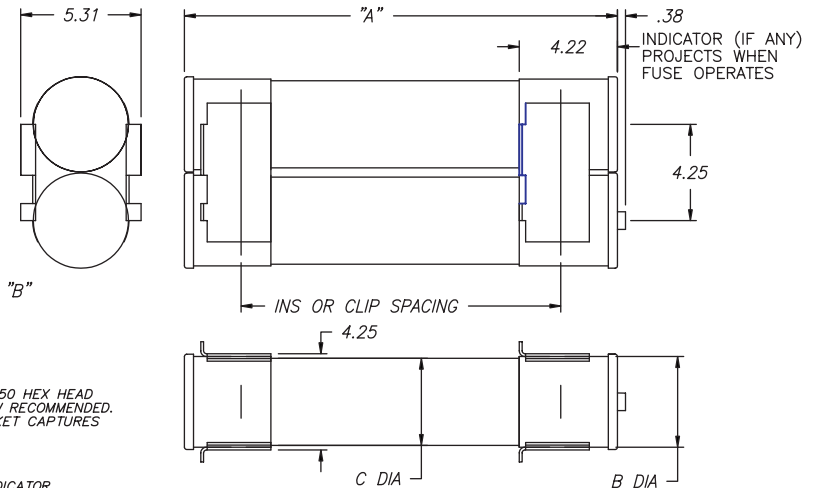

FIG 104

NOTE: DIMENSIONS FOR REFERENCE ONLY

REVISIONS	CPO-V		CPO-WEB		PRINTS TO
	NO	DATE	NO	DATE	
1	K. Carroll	03-Apr-97			
	Updated to CPO-Outline Format				
2	K. Carroll	10-May-97			
	Added P48 ECN#K48				
3	K. Carroll	17-Nov-97			
	Updated Routing ECN #K77				
4	T. Grant	8/29/01			
	Updated list, ECN #K150 and added NOTE				
MADE BY: J. S. Ryan 12-May-41		APPROVALS: Kris Ranjan 8/31/01		32B608009	
ISSUED BY: K. Carroll 17-November-97				CONT ON SH SH 2	