

On Board Disconnectors HAS range 25kV (1000Amp)

ON BOARD DISCONNECTOR SWITCH

25KV ON BOARD DISCONNECTORS SWITCH

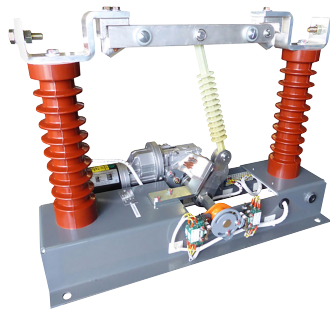

For more than 100 years, Mersen have been providing the market with safe, reliable and longer life time off-load disconnectors. These devices offer high performances and robustness for heavy duty requirements with very limited maintenance.

Mersen offers one of the largest product ranges on the market and is the global leader. Mersen has a switch solution that will meet your unique needs.

Our standard HAS High Power Switches are rigorously engineered to meet your technical specifications.

Operation : They can be operated manually or with an adapted motor (see list) up to 25.000 cycles.

Signaling, Terminal Box or Locking system can be studied and customised.

Small making or braking capacity (under request)

Maximum frequency up to 175Hz

Indoor in a currentless state

TECHNICAL DATA OVERVIEW

Size per Standard	HAS 1000A (higher rating on request)
Speed/Characteristic	Around 5 sec with motor operation
Working Temperature	-20°C to +70°C (-40°C upon request)
Number of Poles	1, more under request
Humidity	95% Max.

FEATURES & BENEFITS

- No Load Operation
- Indoor Type - Horizontal axis mounting
- Configuration with 1 pole
- Mechanical endurance : 25.000 cycles (1 cycle = open + close)
- Temperature rise at nominal current is less than 60°K (with 40°C max. ambient temperature)
- Electrical contact by contact blades with pressed-on Hard Silver Contact Rivets and silver-plated
- Supporting insulators made of cast epoxy resin (fire classification according to UL94-V1)
- Large isolation air and creepage path
- Self-cleaning blade contacts
- True opening and visible distance
- Rugged anti-torsion construction
- Full customisation with :
 - Manual, motor
 - Auxiliary switches, blocking magnets, locking devices
 - Dimensions and Fitting

APPLICATIONS

- On Board Disconnector for 25kV Locomotives



On Board Disconnectors HAS range 25kV (1000Amp)

PRODUCT RANGE

HAS Range 25kV

Catalog number	Rated current I_n	Rated peak current	RMS 1 sec short-time withstand current	Voltage drop	Weight
HAS101P1000A25KV	1000 A	75 kA	30 kA	35 mV	60 kg

DIMENSIONS

25kV Disconnector 1 pole 1000VDC motorized (dwg 1020376)

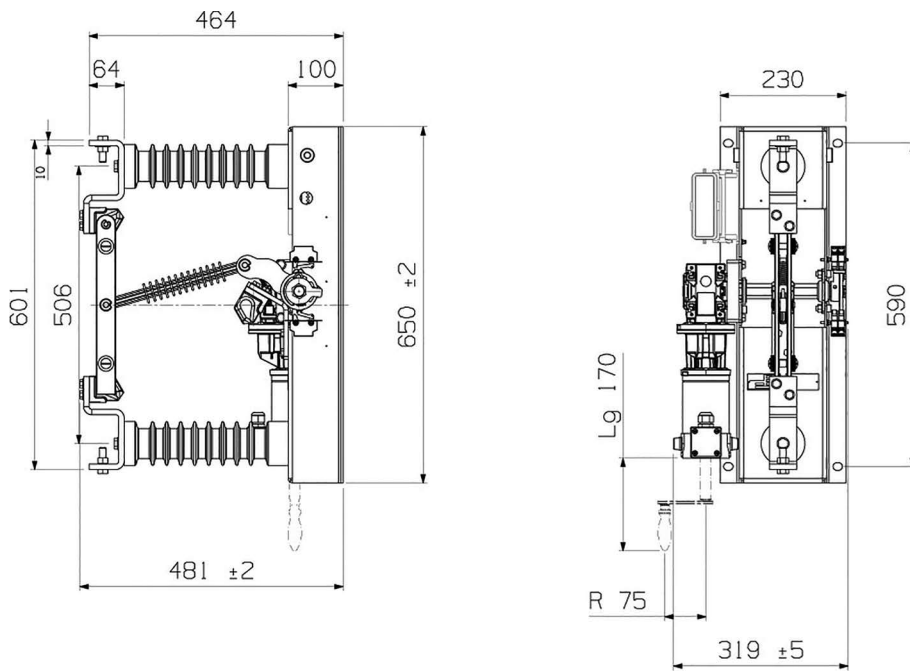

MOTORS

Motor types	Code	Motor voltage rating
AC Mono	Code A 50Hz	230VAC
	Code B 60Hz	220VAC
AC 3 phases	Code C 50Hz	400VAC
	Code D 60Hz	400VAC
DC	Code G	110VDC
		220VDC

On Board Disconnectors HAS range 25kV (1000Amp)

FUNCTIONS

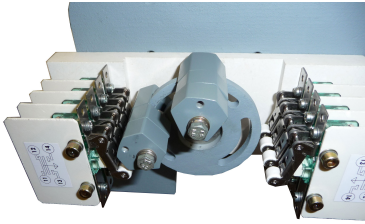

Customized signaling

This range can be equipped with micro switches offering 10 Amp under 400VAC (or DC13 110VDC 0,5Amp) and 10 million cycles operation.

These microswitches are used to signal the switch position and also to cut the power of the motor when it arrives at the end of its operation.

The disconnectors can be equipped with 1, 2, 3 microswitches (more under study).



Temperature range

This range can be designed to be installed in severe environment with temperature range down to -40°C (lower temperature upon request).



Tropicalized version

This range can be designed to be installed in salty atmospheres and in tropical geographical zones using stainless steel and a tropicalized version of motor or microswitches and special paints.

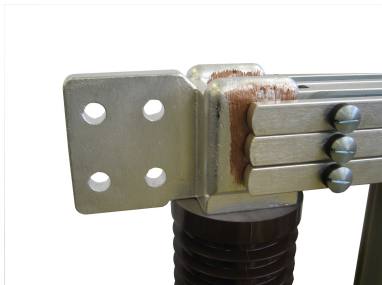

Connection plate adaptation

To adapt the disconnector to the Busbar, we can adapt the orientation of the connecting plates (Vertically or Horizontally)

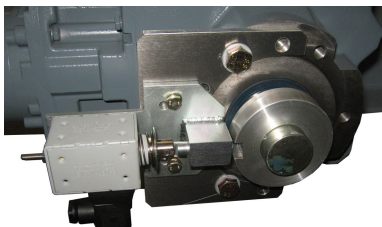

Blocking magnets

The disconnector in this range have their position secured in Open and Closed (or both) positions using various locking systems for complete security.

- Padlocking (1 padlock diam 6mm)
- Key locking using preferably a Ronis Lock
- Blocking Magnets

On Board Disconnectors HAS range 25kV (1000Amp)

FUNCTIONS

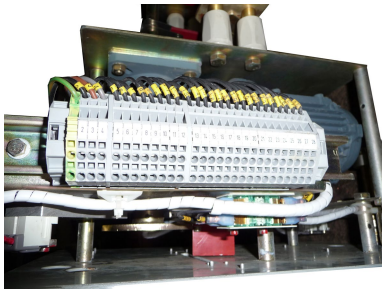

Connection box, Connection Terminal

Blocking magnets are used to guarantee electromechanically the position of the Disconnector using remote control. This operation can be done for one or both position (open and closed).

Blocking magnet can be used missing Voltage or Voltage can be 24VDC, 48VDC, 110VDC, 230VDC and 230VAC (consumption GE40; TGN15; TGN17 between 20 to 45W)



Mechanical Operation Counter

This Disconnector range can be equipped with a wiring connection terminal or connection box.

ACCESSORIES



W110902

Indication facilities

Catalog number	Item number	Length	Package	Weight
MECHANICAL OPERATION COUNTER	W110902	63 mm	1 piece	0.5 kg

Microswitches

Catalog number	Item number	Package	Weight
Microswitches			
S/E SGN 2 CA SW11	D1030058	1 piece	0.3 kg
S/E SGN 4 CA SW11	D1027229	1 piece	0.35 kg
S/E SGN 6 CA SW11	L1027489	1 piece	0.4 kg
S/E SGN 8 CA SW11	B1028952	1 piece	0.5 kg

Supplementary poles

Catalog number	Rated current I _n	Package	Weight
S/E POLE HAS 1000A U74	1000 A	1 piece	6.2 kg

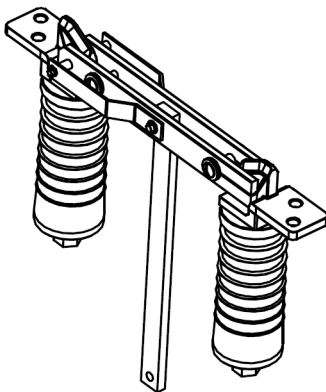

On Board Disconnectors HAS range 25kV (1000Amp)

ACCESSORIES

Lubricants

Catalog number	Item number	Package	Weight
Copper Grease	L108501	1 piece	1 kg

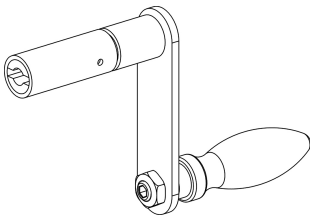

R817113

Removable handles for emergency manual operation

Catalog number	Item number	Length	Package	Weight
ARB FLEX SSB-7 1043	P1013646	1.043 m	1 piece	0.5 kg
LIMITING TORQUE MAN D10 L170	Z819305	0.17 m	1 piece	0.46 kg
S/E MANIVELLE D10.2 170	R817113	0.17 m	1 piece	0.27 kg
S/E MANIVELLE D10.2 170 Tropical	N827782	0.17 m	1 piece	0.27 kg
S/E MANIVELLE D10.2 300	Z817143	0.3 m	1 piece	0.29 kg
S/E MANIVELLE D10.2 480	Q822103	0.48 m	1 piece	0.33 kg
S/E MANIVELLE D10.2 600	E834168	0.6 m	1 piece	0.6 kg
S/E MANIVELLE D10.2 1000	L827688	1 m	1 piece	0.6 kg
S/E SGN CDE SECOURS FLEX 1043	W1013652	1.043 m	1 piece	0.7 kg

Manual operation handles

Catalog number	Item number	Length	Package	Weight
S/E EYE LEVER D30/30 L450	H821728	450 mm	1 piece	0.7 kg
ISOLATING STICK L1120 20KV	L820190	1120 mm	1 piece	0.85 kg
ISOLATING STICK L1520 45KV	V908380	1520 mm	1 piece	1 kg
ISOLATING STICK L2020 60KV	W908381	2020 mm	1 piece	1.25 kg



H821728

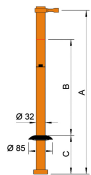

V908380

MERSEN reserves the right to change, update or correct, without notice, any information contained in this datasheet.